

Reducing Greenhouse Gas Emissions from Deforestation in Developing Countries: Considerations for Monitoring and Measuring

Prepared by
Ruth DeFries, Frédéric Achard, Sandra Brown, Martin Herold,
Daniel Murdiyarso, Bernhard Schlamadinger, Carlos de Souza Jr.

August 2006



GOFC-GOLD Report No. 26

GTOS Report No. 46

Global Observation of Forest and Land Cover Dynamics (GOFC-GOLD) is a coordinated international effort to ensure a continuous program of space-based and in situ forest and other land cover observations to better understand global change, to support international assessments and environmental treaties and to contribute to natural resources management.

GOFC-GOLD encourages countries to increase their ability to measure and track forest and land cover dynamics by promoting and supporting participation on implementation teams and in regional networks. Through these forums, data users and providers share information to improve understanding of user requirements and product quality.

GOFC-GOLD is a Panel of the Global Terrestrial Observing System (GTOS), sponsored by FAO, UNESCO, WMO, ICSU and UNEP. The GOFC-GOLD Secretariat is hosted by Canada and supported by the Canadian Space Agency and Natural Resources Canada. Other contributing agencies include NASA, ESA, START and JRC. Further information can be obtained at

<http://www.fao.org/gtos/gofc-gold>



GTOS

land cover

Global Observation of Forest and Land Cover Dynamics

GTOS 46

GOLD 26

Reducing Greenhouse Gas Emissions from Deforestation in Developing Countries: Considerations for Monitoring and Measuring

Reducing Greenhouse Gas Emissions from Deforestation in Developing Countries: Considerations for Monitoring and Measuring

Prepared by

Ruth DeFries¹, Frédéric Achard², Sandra Brown³, Martin Herold⁴, Daniel Murdiyarso⁵, Bernhard Schlamadinger⁶, Carlos de Souza Jr.⁷

¹*Department of Geography and Earth System Science Interdisciplinary Center, University of Maryland, College Park, MD 20742 USA email: rdefries@mail.umd.edu*

²*Institute for Environment and Sustainability Joint Research Centre of the European Commission, 21020 Ispra (VA), Italy*

³*Winrock International – Ecosystem Services Unit 1621 N. Kent Street, Suite 1200, Arlington, VA 22207, USA*

⁴*GOFC-GOLD Land Cover Office, Department of Geography, Friedrich Schiller University Jena, Loebdergraben 32, 07743 Jena, Germany*

⁵*CIFOR Headquarter, P.O. Box 6596, JKPWB, Jakarta 10065, Indonesia*

⁶*Joanneum Research, Elisabethstrasse 5, 8010 Graz, Austria*

⁷*Instituto Homem e Meio Ambiente da Amazônia – Imazon, Caixa Postal 5101, Belém, PA, 66613-397, Brazil*



GTOS Secretariat

SDRN, Food and Agriculture Organization of the United Nations (FAO)
Viale delle Terme di Caracalla, 00100 Rome, Italy

Tel.: (+39) 06 57052565

Fax: (+39) 06 57053369

E-mail: gtos@fao.org

GOFC-GOLD Project Office

Natural Resources Canada / Canadian Forest Service
Northern Forestry Centre, 5320 - 122 Street, Edmonton, Alberta T6H 3S5 CANADA

Tel.: (+1) 780 4357210

Fax: (+1) 780 4357359

E-mail: GOFC-GOLD@nrca.gc.ca

Land Cover Team Implementation Office

Friedrich-Schiller-University Jena, Institute of Geography
Department of Geoinformatics, Löbdergraben 32, 07743 Jena, Germany

Tel.: (+49) 3641 948887

Fax: (+49) 3641 948882

E-mail: m.h@uni-jena.de

Contents

Acronyms..... 2

Executive Summary..... 3

1. Context of this Report..... 5

2. Monitoring Deforested Area 6

 2.1. Technical Methods for Deforestation Monitoring 7

 2.2. National Capacity for Deforestation Monitoring 10

 2.3. Accuracy and Verification of Deforestation Monitoring..... 10

 2.4. Data Availability and Access 11

3. Monitoring Forest Degradation 12

4. Monitoring Changes in Carbon Stocks 13

5. Estimating Averted GHG Emissions from Reduced Deforestation at the National Level..... 15

6. Recommendations 16

References 17

APPENDIX ONE: Participants of the GOFC-GOLD workshop held in March 2006 in Jena, Germany 20

Suggested citation:

DeFries, R., Achard, F., Brown, S., Herold, M., Murdiyarso, D., Schlamadinger, B. and C. De Souza 2006. Reducing Greenhouse Gas Emissions from Deforestation in Developing Countries: Considerations for Monitoring and Measuring, Report of the Global Terrestrial Observing System (GTOS) number 46, GOFC-GOLD report 26, available: www.fao.org/gtos/pubs.html, 23p.

Acronyms

ALOS	Advanced Land Observing Satellite
ASAR	Advanced Synthetic Aperture Radar
AWiFS	Advanced Wide Field Sensor
CBERS	China-Brazil Earth Resources Satellite
COP	Conference of the Parties
ERS	European Remote Sensing Satellite
FAO	Food and Agriculture Organization of the United Nations
FSI	Forest Survey of India
GHG	Greenhouse gas
GOFC-GOLD	Global Observation of Forest Change – Global Observation of Land Dynamics
GTOS	Global Terrestrial Observing System
HRV	High Resolution Visible
INPE	Instituto Nacional de Pesquisas Espaciais (Brazilian National Institute for Space Research)
IPCC	Intergovernmental Panel on Climate Change
IRS	Indian Remote Sensing Satellite
JERS	Japan Earth Resources Satellite
LISS	Linear Imaging and Self Scanning sensor
LULUCF	Land-use, land-use change and forestry
MERIS	Medium Resolution Imaging Spectrometer
MODIS	Moderate Resolution Imaging Spectroradiometer
NASA	National Aeronautics and Space Administration
PALSAR	Phased Array type L-band Synthetic Aperture Radar
PRODES	Programa de Cálculo do Desflorestamento da Amazônia (Monitoring project of the Brazilian Amazon forest by satellite)
SAR	Synthetic Aperture Radar
SBSTA	Subsidiary Body for Scientific and Technological Advice
SPOT	Satellite Probatoire d’Observation de la Terre
UNFCCC	United Nations Framework Convention for Climate Change

Executive Summary

Official international discussions initiated at the 11th UNFCCC Conference of Parties (COP) in December 2005 focused on issues relating to reducing greenhouse gas (GHG) emissions from deforestation in developing countries. The resulting COP-11 decision established a process for submitting recommendations on implementation of policies to reduce GHG emissions from deforestation in developing countries and for examining related scientific, technical and methodological issues. **This report highlights technical considerations for the measuring and monitoring of reductions in greenhouse gas emissions from avoided deforestation that need to be addressed in more detailed guidelines and protocols.**

Quantifying GHG emissions averted from reduced deforestation requires measurements of changes in forest cover and associated changes in carbon stocks. Analysis of remotely sensed data from aircraft and satellite is the only practical approach to measure changes in forest area at national and international scales. **Since the early 1990s, changes in forest area can be measured from space with confidence.**

Various methods are available and appropriate to analyze satellite data for measuring changes in forest cover. These methods range from visual photo-interpretation to sophisticated digital analysis, and from wall-to-wall mapping to hot spot analysis and statistical sampling. A variety of methods can be applied depending on national capabilities, deforestation patterns, and characteristics of forests. Quantifying the accuracy of the result and ensuring that consistent methods are applied at different time intervals is more critical than applying standard methods across all countries.

Removal of forest cover through deforestation is the primary contributor to GHG emissions from changes in forest areas. **Forest degradation from high impact logging, shifting cultivation, wildfires, and forest fragmentation also contribute to GHG emissions.** Measuring forest degradation from satellites is more technically challenging than measuring deforestation but methods are becoming available.

Carbon stock estimates of forests undergoing deforestation and the subsequent carbon dynamics are uncertain for many developing countries. Default data and guidelines for carbon accounting already exist in the IPCC Good Practice Guidance Report (Penman *et al.* 2003a) and the upcoming revised IPCC methods for national inventories of GHGs (Paustian *et al.* 2006). New technologies and approaches are being developed for monitoring changes in carbon stocks using a combination of satellite and airborne imagery that will potentially reduce uncertainties in accounting for changes in GHG emissions from deforestation. International coordination is needed to further test and implement these technologies.

Several developing countries have operational systems in place for monitoring deforestation at national scales, notably India and Brazil. Other

countries, such as Bolivia, Indonesia and Peru have gained experience in project based studies and have demonstrated capabilities to develop national systems.

Key constraints in implementing national systems for monitoring changes in forest cover are cost and access to high resolution data. International coordination is needed to ensure repeated coverage of the world's forests and access to quality data at a reasonable cost. Reliable and up-to-date data sources on the national distribution of carbon stocks in forests and changes in stocks under local practices of clearing and degradation is also needed. There is limited capacity in many developing countries to acquire and analyze the data needed for a national system of GHG reporting for deforestation and degradation.

Data sources exist to determine base periods in the 1990s as historical reference points. Averted emissions can be estimated from short term (approximately 5 to 10 years) extrapolations of current trends and historical deforestation rates and from existing estimates of forest carbon stocks.

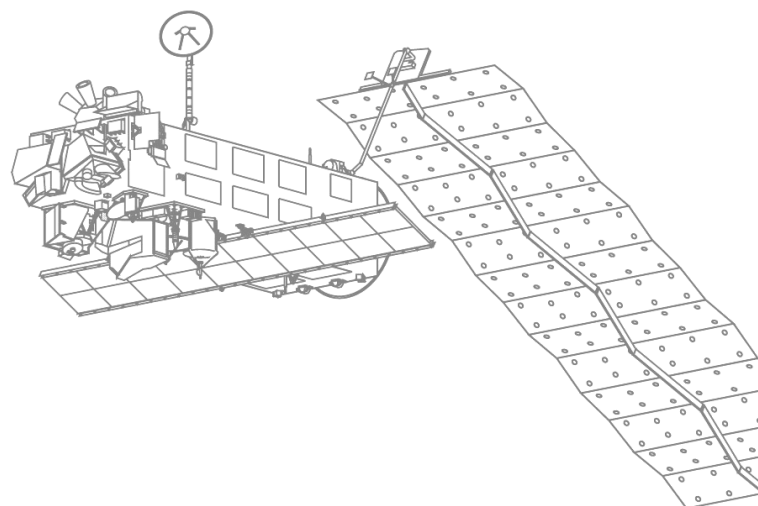

1. Context of this Report

Official international discussions were initiated at the 11th UNFCCC Conference of Parties (COP) in December 2005 on issues relating to reducing emissions from deforestation in developing countries (Agenda item 6). No such policies are currently in place during the first commitment period of the Kyoto Protocol for countries without commitments, i.e. presently non-Annex I countries. The COP requested the Subsidiary Body for Scientific and Technological Advice (SBSTA) to consider the relevant scientific, technical, and methodological issues and report at SBSTA's 27th Session in December 2007.

This report was prepared by "Global Observations of Forest Cover and Land Dynamics" (GOFC/GOLD - Townshend and Brady 2006), a technical panel of the Global Terrestrial Observing System (GTOS), as outcome of an established working group on this issue and a related workshop held in March 2006 (Herold *et al.* 2006, Appendix A). The objective is to assess technical capabilities for estimating emissions from deforestation in developing countries as input to the SBSTA. The report raises key issues that need to be addressed in further development of more detailed guidelines and protocols.

Implementation of policies to reduce emissions from deforestation depends on accurate and precise estimates of emissions averted at the national scale (Santilli *et al.* 2005). Several components must be estimated: 1) loss of forest cover at the national level; 2) initial carbon stocks for the base period and their change caused by deforestation and degradation, and 3) emissions averted from a defined "baseline" or base period.

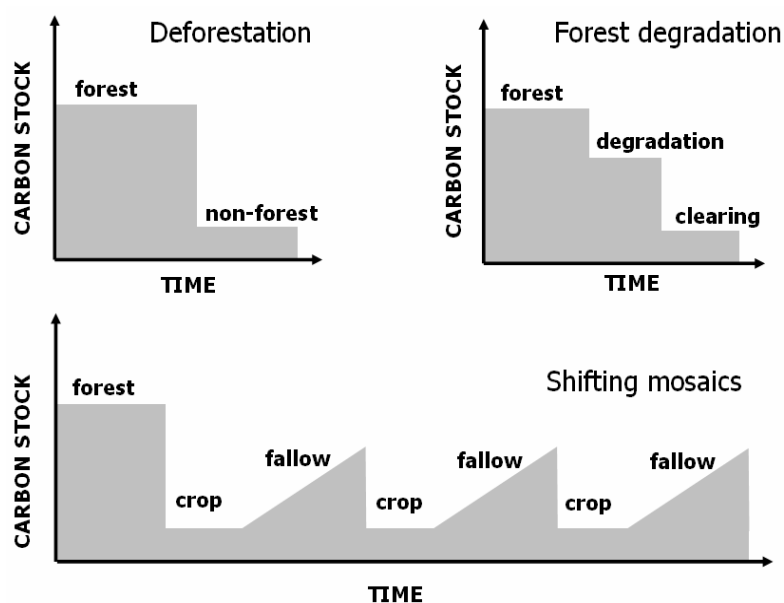

Figure 1: Changes in carbon stocks from different forest land use practices: deforestation, forest degradation, and shifting mosaics

Remote sensing combined with ground measurements play a key role in determining the loss of forest cover. Technical capabilities have advanced since the early 1990s and operational forest monitoring systems at the national level are now a feasible goal for most developing countries (Mollicone *et al.* 2003, DeFries *et al.* 2005). Progress is also occurring in the development of new technologies and approaches to remotely sense forest carbon stocks using airborne sensors (e.g. Drake *et al.* 2003, Brown *et al.* 2005). Although the latter is more in the development stage, they will potentially be operational within the time frame of the next commitment period.

Multiple land use practices in forests lead to the loss of carbon stocks and emissions of carbon dioxide, and if the biomass is burned during the clearing process, additional non-CO₂ gases are emitted (Penman *et al.* 2003a). Deforestation, defined as the conversion of forest land to non-forest land (considering the UNFCCC definitions of forest) is most easily monitored and causes a relatively large loss of carbon stock per deforested area (Figure 1). Forest degradation practices such as unsustainable timber production, over harvesting of fuel wood, and fires at the edge of forest fragments are less easily observed than deforestation but can contribute substantially to emissions. Forest degradation can also be a precursor to deforestation. On the other hand, some land use practices in forests, such as managed logging and shifting cultivation, result in a shifting mosaic of cleared areas without long-term net emissions unless the land use expands into previously intact forest areas or the shifting cultivation cycle is shortened. These multiple changes in land use and forest area need to be monitored at the national level.

This report considers this range of issues and addresses considerations for monitoring deforestation and forest degradation, evaluating changes in carbon stock, and estimating averted emissions.

2. Monitoring Deforested Area

Monitoring to support policies for reducing deforestation requires the capability to measure changes in the forest area throughout all forests within a country's boundaries. Nationwide monitoring is needed to avoid displacement or leakage within a country where reduced deforestation could occur in one portion of the country but increase in another. Fundamental requirements of monitoring systems are that they measure changes throughout all forested areas¹ within the country, use consistent methodologies at repeated intervals to obtain accurate results, and verify results with ground-based or very high resolution observations.

¹ For this discussion we use the definition of forest adopted by COP-6 for implementation of article 3: "Forest is a minimum area of land of 0.05 – 1.0 hectares with tree crown cover (or equivalent stocking level) of more than 10-30 percent with trees with the potential to reach a minimum height of 2-5 meters at maturity in situ. A forest may consist either of closed forest formations where trees of various storeys, and undergrowth cover a high proportion of the ground or open forest." COP-6 further noted that parties recognize that there should be certain flexibility in applying the values in order to reflect national circumstances.

The only practicable approach for monitoring deforestation at a national level is through the interpretation of remotely sensed data supported by ground based observations. Remote sensing includes data acquired by sensors on board aircraft and space based platforms. Since the early 1990s, changes in forested areas have been monitored from space with confidence. Some countries, such as Brazil (INPE 2005) and India (Forest Survey of India 2004), have had well-established operational systems in place for over a decade. Some countries are developing these capabilities and others have successfully monitored forests with aerial photographs that do not require sophisticated data analysis or computer resources. A variety of methods that are applicable to varying national circumstances regarding forest characteristics, cost constraints, and scientific capabilities are available and adequate for monitoring deforested area and verifying the accuracy.

2.1. Technical Methods for Deforestation Monitoring

What methods are appropriate for deforestation monitoring at national scales?

There are multiple methods that are appropriate and reliable for monitoring deforestation². The appropriateness of the method depends on the following factors:

- Cost of data and technical capabilities – Where technical capabilities and cost constraints prevent digital analysis, visual interpretation of aerial photographs or satellite images is an appropriate monitoring method. The need for reproducible and verifiable results can be met through multiple interpreters and well-designed procedures. For countries with sophisticated data acquisition and analysis, more automated analysis with computer algorithms reduces the time required for monitoring and strengthens the efficiency of the monitoring system in the long term.
- Clearing size and patterns of deforestation – Clearings for large-scale mechanized agriculture are detectable with medium resolution data (100s of meters spatial resolution) based on digital analysis. Small agricultural or settlement clearings of 0.5-1 hectare require higher resolution data (10s of meters) to be accurately detected. Smaller clearings and more heterogeneous landscapes require greater involvement of an interpreter for visual analysis and more complex computer algorithms that detect less pronounced differences in spectral reflectances.
- Seasonality of forest – For seasonal tropical forests, the appropriate method must ensure that annual climatic variations are not leading to false identification of variations in canopy cover as deforestation. Multiple observations throughout the year may be required. Deforestation in moist evergreen forests could be

² We use the IPCC definition of deforestation adopted by COP-6: "Deforestation is the direct human-induced conversion of forested land to non-forested land". Under current UNFCCC definitions a forest can contain anything from 10 percent to 100 percent tree cover; it is only when cover falls below the minimum crown cover as designated by a given country that land is classified as non-forest. To date, most countries are defining forests with a minimum crown cover of 30 percent.

observed at any time of year and is more dependent on the availability of cloud-free imagery. The use of Radar satellite observations is less operational but can help where appropriate temporal coverage is not available due to cloud cover.

- Overall country size and forest area – It has been demonstrated that estimates of deforestation can be provided through remote sensing based methods at global or continental levels (Achard *et al.* 2002; De Fries *et al.* 2002, FAO 2001) or at national and sub-national levels for very large countries such as Brazil and India (INPE, 2005; FSI, 2004). These methods could be easily adapted to cope with smaller country sizes (see next point). For countries with large forested areas, visual analysis may not be practical and instead a more automated approach is necessary. For countries with smaller forested areas, it may be possible to effectively monitor through visual interpretation and more ground-based data collection.

In summary, no single method is appropriate for all national circumstances. Many methods can produce adequate results. Guidelines and protocols can be developed based on forest types, deforestation patterns, and resources available. The key requirements to ensure consistency of results across countries lies in verification that the methods are reproducible provide consistent results when applied at different times, and meet standards for assessment of mapping accuracy. Accountability of the results and transparency of the methods can be guaranteed through a peer review process.

Are methods available to alleviate the practical limitations of monitoring the entire forested area within a country?

Monitoring for reducing emissions from deforestation can only ensure that leakage does not occur if the full forested area within a country is represented. Analysis that covers the full spatial extent of the forested area, termed “wall-to-wall” coverage, must prevent leakage within the country. Wall-to-wall analysis is ideal, but may not be practical due to large areas and constraints on resources for analysis. Several approaches have been successfully applied to sample within the total forest area to reduce both costs and the time for analysis:

- Identification of areas of rapid deforestation through expert knowledge – Sub-sampling based on knowledge of deforestation fronts identifies areas to be analyzed with high resolution data (Achard *et al.* 2002). Experts with detailed knowledge of the country are needed to ensure that areas of major change are not overlooked. The Brazilian PRODES monitoring system (INPE 2005) identifies “critical areas” based on the previous year’s monitoring to prioritize analysis for the following year. Other databases such as transportation networks, population changes in rural areas, and locations of government resettlement programmes can be used to help identify areas where pressure to deforest is likely to be high and where a more detailed analysis is required.
- Hierarchical, nested approach with medium resolution data – Analysis of medium and coarse resolution data can identify locations of rapid and large deforestation. However, such data are generally unsuitable to determine rates of

deforestation based on changes in forest area (DeFries *et al.* 2002, Morton *et al.* 2005). A nested approach in which medium resolution data is analyzed to identify locations requiring further analysis with more costly high resolution data can reduce the need to analyse the entire forested area within a country (Figure 2).

- Statistical sampling designed to capture deforestation patterns – A sampling procedure that adequately represents deforestation events can capture deforestation trends (Strahler *et al.* 2006). As deforestation events are not randomly distributed in space (Tucker and Townshend 2000), particular attention is needed to ensure that the statistical design is adequately sampling within areas of potential deforestation (e.g. in proximity to roads), and through high density systematic sampling (Mayaux *et al.* 2005).

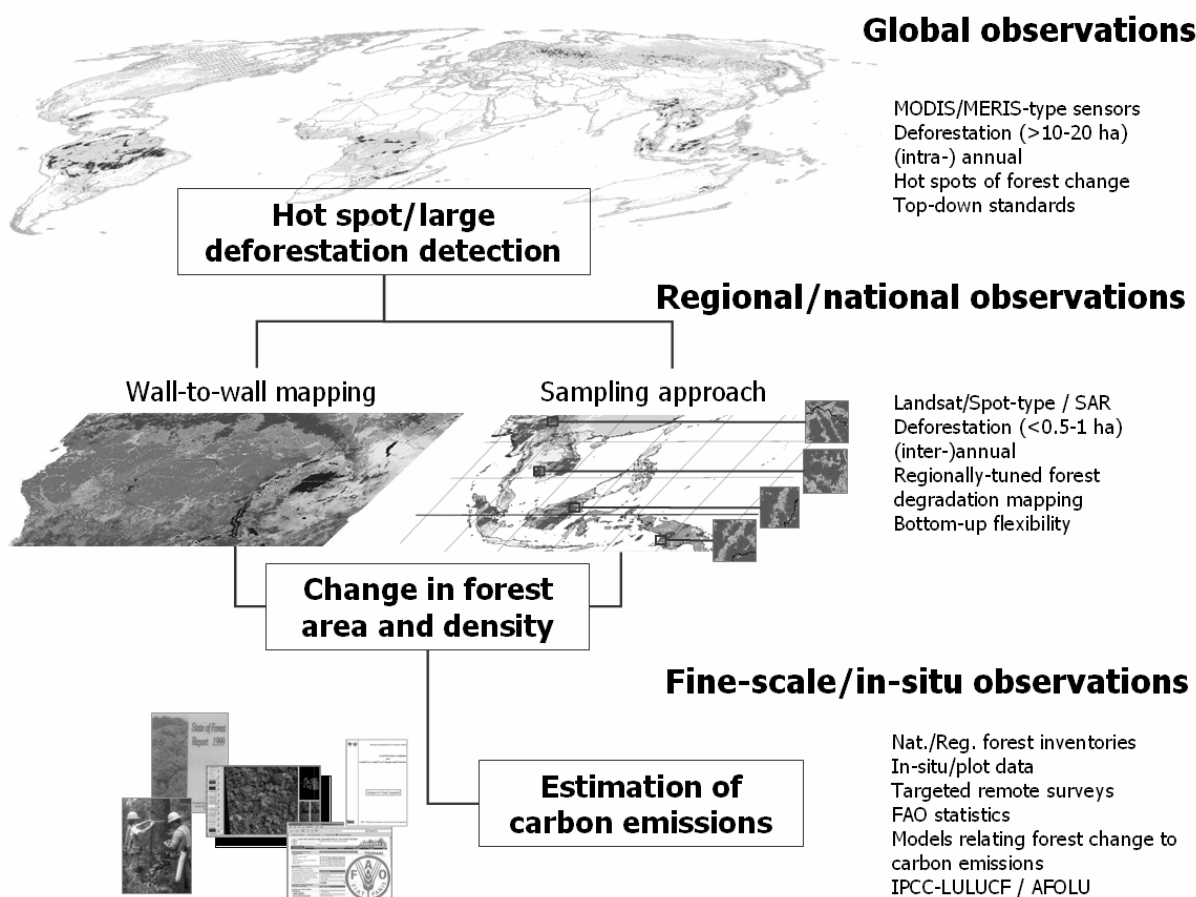

Figure 2: Conceptual observation framework for monitoring forest changes and related carbon emissions integrating information from different data sources

What methods account for shifting cultivation and other temporary clearings to avoid false identification of new deforestation?

Shifting cultivation results in a mosaic of clearings and fallow that change over time. Such clearings, if identified as new deforestation in a monitoring system, would falsely inflate deforestation rates in the long term. A longer time series of repeated observations, combined with expert knowledge of the land use patterns in the country, are needed to distinguish new deforestation from clearing dynamics associated with existing practices. A key requirement for a monitoring system is the initial designation of the forest area under which future clearings are considered new deforestation. Guidelines and protocols for monitoring can be developed to identify and exclude these areas from the analysis using a baseline with annual updates over a minimum time period of five years or ancillary data to designate intact forests. However, the monitoring system needs to be able to identify intensification of the shifting cultivation cycle where the fallow period is shortened (Penman *et al.* 2003a).

2.2. National Capacity for Deforestation Monitoring

Brazil and India are two examples of developing countries with operational systems in place to monitor forest cover. These countries have receiving stations to acquire remote sensing satellite imagery (Landsat or Terra data) and/or national satellites (IRS or CBERS, respectively). Other countries have carried out forest assessments using remote sensing products including Peru, Bolivia, Indonesia and others.

A key constraint on other countries in developing similar capabilities is access to data at a reasonable cost and the technical infrastructure (hardware, software, and internet access). Technical capabilities vary, but many countries are developing sufficient expertise to enable monitoring systems. Regional partnerships for acquiring and developing appropriate methods can help address some of the needs.

The principal monitoring requirement to support policies for reducing deforestation falls at the national level. Analyses coordinated at an international level that spans the tropics, using coarser resolution data than would be used at the national level, can supplement these efforts by providing consistency and ensuring that major areas of deforestation are detected. Products such as those derived from medium resolution data can be used for such detection (Hansen *et al.* 2003, Hansen *et al.* 2005).

2.3. Accuracy and Verification of Deforestation Monitoring

Reporting accuracy and verification of results are essential components of a monitoring system. Accuracies of 80 to 95 percent are achievable for monitoring with high resolution imagery to discriminate between forest and non-forest. Accuracies can be assessed through in-situ observations or analysis of very high resolution aircraft or satellite data. In both cases, a statistically valid sampling

procedure (Strahler *et al.* 2006) can be used to determine accuracy. An accuracy assessment is feasibly conducted on a forest/non-forest map at one time. While it is difficult to verify change from one time to another on the ground unless the same location is visited at two different time periods, a time series of very high resolution data can be used to assess the accuracy of identifying new deforestation.

As different methods are applicable in different countries, verification of the monitoring by a third party would include a review of the appropriateness of the method for the particular forest conditions and deforestation patterns, consistency in the application of the method, adherence to data management standards, and methods for assessing accuracy of the result.

Table 1. Utility of optical sensors at multiple resolutions for deforestation monitoring*

Sensor resolution	Examples of current sensors	Utility for monitoring	Cost
Very high (<5m)	IKONOS, QuickBird	Validation over small areas of results from coarser resolution analysis	Very high
High (10-60m)	Landsat, SPOT HRV, AWiFs LISS III, CBERS	Primary tool to identify deforestation	Low/medium (historical) to medium/high (recent)
Medium (250-1000m)	MODIS, SPOT Vegetation	Consistent global annual monitoring to identify large clearings (>10-20 ha) and locate "hotspots" for further analysis with high resolution	Low or free

* Data from optical sensors have been widely used for deforestation monitoring. Data from Lidar and Radar (ERS1/2 SAR, JERS-1, ENVISAT-ASAR and ALOS PALSAR) have been demonstrated to be useful in project studies, however, so far they are not widely used operationally for tropical deforestation monitoring.

2.4. Data Availability and Access

High resolution data with nearly complete global coverage is available at low or no cost for the early 1990s and the early 2000s, in particular Landsat satellite data

from NASA (<https://zulu.ssc.nasa.gov/mrsid>) or from the University of Maryland's Global Land Cover Facility (<http://glcfapp.umiacs.umd.edu/>) (Mollicone *et al.* 2003). These data sets serve a key role in establishing historical deforestation rates, though in some parts of the tropics (e.g. Central Africa) persistent cloudiness is a major limitation to using these data. Medium resolution data are available for no cost from 2000 onwards.

Despite these data sources, the key constraints for monitoring deforestation are adequate coverage of tropical forests in the current decade, coordination of observations to ensure tropical forest coverage in the future, and access to data. The cost of high resolution data is currently a limitation for many countries in establishing monitoring systems. Ensured data access through international coordination is needed for countries to implement monitoring systems to support policies for reducing deforestation.

Optical high resolution data has been the primary tool for deforestation monitoring (Table 1). Other types of sensors, e.g. Radar and Lidar, are potentially useful and appropriate. Radar, in particular, alleviates the substantial limitations of optical data in persistently cloudy parts of the tropics and has been demonstrated to be useful for mapping tropical forests (Rosenqvist *et al.* 2000, DeGrandi *et al.* 2000, Siegert *et al.* 2001). Lidar data have not been available with global coverage and thus their application to deforestation monitoring is limited. In the timeframe of the next commitment period, the utility of Radar and Lidar may be enhanced depending on data acquisition, access and scientific developments.

3. Monitoring Forest Degradation

There are many definitions of forest degradation relating to canopy cover, ecological function, carbon stocks, and other attributes of forests (Penman *et al.* 2003a and 2003b). Of these definitions, degradation defined by changes in canopy cover is the most readily observable with remote sensing.

Forest degradation results from human activities that partially remove forest biomass in an unsustainable manner. Though carbon emissions may not be as large per unit area as the complete removal of forest through deforestation, forest degradation occurs over large areas and can contribute significantly to overall emissions from forest loss (Asner *et al.* 2005). With the UNFCCC definition of forest greater than 10 percent tree cover, substantial loss of tree cover can occur through degradation while maintaining designation as "forest." A location would not be considered non-forest until forest cover fell below the canopy threshold. Moreover, forest degradation may enhance susceptibility to fire and may result in a substantial loss of below-ground carbon in peat areas. Degradation is often a precursor to deforestation as areas that are logged often increase access and result in clearing.

Monitoring degradation is more technically challenging than monitoring deforestation. Differences in reflectances between forest and degraded forest are more subtle than in the case of deforestation, and degradation patches are

generally small compared with clearings. For these reasons, methods for monitoring degradation are not as well established as those for monitoring deforestation.

What processes lead to forest degradation?

Degradation results directly from human uses of forest as well as from the indirect results of human activity. Managed and unplanned selective logging leaves forest gaps, although reduced impact logging greatly minimizes these effects. Woody removal for wood fuels, particularly charcoal, can result in degradation. Edges of forest fragments exposed through deforestation and logging leaves the forest susceptible to degradation through understory fires. All of these processes promote the loss of forest cover and carbon stocks, which can be the first step towards total forest loss through deforestation.

Are methods available to monitor forest degradation?

Methods to identify forest degradation use high resolution data. Radar data can potentially detect degradation though this application needs further development. There are methods to detect canopy damage through visual interpretation. Spatial patterns of log landings and identification of other infrastructure has been a successful approach for identifying degradation (Matricardi *et al.* 2001, Asner *et al.* 2005, Souza Jr. *et al.* 2005). Likewise deforestation and canopy damage due to forest degradation can be mapped with different techniques, varying from visual interpretation to advanced image processing algorithms. Active fire detection can also indicate the presence of burn scars. An effective solution for distinguishing between a simple definition of degradation (intact versus non-intact forests) has recently been proposed to take advantage of existing observational approaches given the current limitation in knowledge on the spatial distribution of biomass (Mollicone *et al.* 2006).

The capabilities to monitor degradation have been demonstrated through pilot projects, and show promise for implementation in operational monitoring systems. Annual monitoring may be needed to capture the dynamics associated with degradation. As is the case with deforestation monitoring, the key constraint is data continuity of high resolution imagery.

4. Monitoring Changes in Carbon Stocks

Carbon emissions from deforestation and degradation depend not only on the area of forest change but also on the associated biomass loss (Brown 2002). The IPCC has compiled methods and good practice guidance (Penman *et al.* 2003a) for determining carbon stock changes in association with national inventories of GHG emissions for changes in Land Use, Land Use Change, and Forestry (LULUCF) and with carbon sequestration projects in the first commitment period. With the updated version of the IPCC guidelines for conducting national GHG emissions from the LULUCF sector (Penman *et al.* 2003a, Paustian *et al.* 2006), methods are

available for estimating GHG emissions from deforestation at the national and project scales.

Table 2. Products for estimating change in carbon stocks from deforestation

Product	Scale	Weaknesses	Degree of uncertainty	Cost (1-3; low to high)
1. Traditional forest inventories	National or regional	Many existing inventories are out of date and very few more recent ones exist Often focused on forests of commercial value	Depends on age of inventory and if updated—low to medium confidence based on date of inventory	3
2. Forest inventory with additional data on canopy cover/type and related to high resolution RS data; update biomass stocks with new high resolution RS data interpreted for change in canopy density (models relate canopy density to biomass)	National to regional	Often focused on forests with commercial value	High to medium confidence	Costly initially to get field inventory (3), reducing costs with updates (2-1)
3. FAO data	National and subregion	Default data	Low confidence	1
4. Compilation of "ecological " plot data	Selected locations	Not sampled from population of interest	Low confidence	1

There are currently no standard practices or capabilities for measuring forest biomass through remote sensing at regional and national scales. Pilot studies using

airborne Lidar data and very high resolution optical data have been used in a sampling approach to estimate biomass of different forest types (Drake *et al.* 2003, Brown *et al.* 2005). High resolution digital optical data can be used to obtain key metrics of individual trees in the forest canopy, and new tools are being developed to automatically delineate tree crown areas in complex tropical forests. In addition, new field data for developing allometric models for converting data from such products to estimates of biomass stocks will need to be acquired and relationships between remotely-sensed metrics of tree canopies and biomass will need to be established. These methods currently are costly, though more cost effective than traditional large field-based forest inventories, but not sufficiently developed for widespread operational use. Experimental data from Radar observations reveal potential for biomass mapping.

Based on current capabilities, emissions from deforestation can be estimated from various sources on carbon stocks in the above-ground biomass of trees (Table 2) and from other forest pools using models and default data in the IPCC Good Practice Guidelines report (Penman *et al.* 2003a). Forest inventories can provide biomass values according to forest type and use, such as mature forest, intensely logged, selectively logged, fallow, etc. Many developing countries do not have sufficient forest inventories. The FAO data, though low confidence, is a default value for national carbon stock with some stratification into main ecological zones (FAO 2006). Compilation of data from ecological or other permanent sample plots may provide estimates of carbon stocks for different forest types, but are subject to the design of individual scientific studies.

A variety of methods and models have been developed using a combination of remote sensing products, spatial data-bases of key factors that are related to forest biomass (e.g. precipitation, temperature, elevation, growing season length, etc.), and field-based forest inventories to derive maps of estimated forest biomass at large regional scales (e.g. Africa-Gaston *et al.* 1998; Asia-Brown *et al.* 1993, and Brazilian Amazon-Houghton *et al.* 2001, Saatchi *et al.* in press).

Guidelines and appropriate practices for using these currently available sources of information on carbon stocks are available in the IPCC Good Practice Guidelines report (Penman *et al.* 2003a). Application of remote sensing data to improve biomass estimates is potentially useful but depends on international commitments to provide resources to deploy new sensors, acquire high resolution airborne imagery, data access, and new field-based data for converting metrics from the imagery to biomass estimates.

5. Estimating Averted GHG Emissions from Reduced Deforestation at the National Level

Combining measurements of changes in forest area with estimates of changes in carbon stocks enables an estimation of emissions from deforestation over large regions (DeFries *et al.* 2002, Achard *et al.* 2004, Houghton 2005, Ramankutty *et al.*

in press). The IPCC has established methods for estimating carbon emissions as well as non-CO₂ GHGs at the national and project scales (see above, Penman *et al.* 2003a and Paustian *et al.* 2006).

Guidelines and protocols need to be established to determine historical estimates/measurements and to develop agreed-upon baselines or base intervals (e.g. using model interpolations of scenarios such as business as usual or expected deforestation trends). The time period for determining the historical quantities and emissions trajectory needs to recognize the large inter-annual variability in deforestation rates and be based on multiple rather than a single year's deforestation results. Unlike with fossil fuel emissions, it is problematic to extrapolate GHG emissions from a given year because inter-annual variability is high. Rather, the base period should encompass at least five or ten years in the recent past.

Projections of future deforestation trajectories are challenging due to the complexity of factors that drive deforestation, including roads and other infrastructure, international economic demands, and national circumstances (Geist and Lambin 2002). These complexities underscore the difficulties in using land use modeling to determine future deforestation rates based on current capabilities. Approaches based on historical estimates and/or future targets can be developed as reference points to determine averted emissions. Historical statistical data collected at the national level may be verified and used to construct deforestation rates for the base year.

6. Recommendations

We recommend the following urgent actions to improve the capabilities for monitoring and measurement systems of reduced greenhouse gas emissions due to deforestation:

- Development of pilot projects dedicated to gaining experience and establishing a deforestation monitoring system at a sub-national to national scale.
- Compilation of existing satellite imagery for quality (cloud free for example) and suitability for developing accurate base periods for major countries in all three tropical regions.
- Assess national capacities and capabilities for analysing data on land cover change and carbon stocks and start to improve them.
- Support developing countries to build historical deforestation data bases.
- Continue to build forest inventory-type databases linking forest area/density change to changes in carbon stocks.

References

- Achard, F., H. Eva, H. J. Stibig, P. Mayaux, J. Gallego, T. Richards, and J. P. Malingreau. 2002. Determination of deforestation rates of the world's humid tropical forests. *Science* **297**:999-1002.
- Achard, F., H. D. Eva, P. Mayaux, H.-J. Stibig, and A. Belward. 2004. Improved estimates of net carbon emissions from land cover change in the tropics for the 1990s. *Global Biogeochemical Cycles* **18**:doi:10.1029/2003GB002142.
- Asner, G. P., D. E. Knapp, E. Broadbent, P. Oliviera, M. Keller, and J. Silva. 2005. Selective logging in the Brazilian Amazon. *Science* **310**:480-482.
- Brown, S. 2002. Measuring carbon in forests: Current status and future challenge. *Environmental Pollution* **116**:363-372.
- Brown, S., T. Pearson, D. Slaymaker, S. Ambagis, N. Moore, D. Novelo, and W. Sabido. 2005. Creating a virtual tropical forest from three-dimensional aerial imagery: application for estimating carbon stocks. *Ecological Applications* **15**:1083-1095.
- Brown, S., L. R. Iverson, A. Prasad, and D. Liu. 1993. Geographic distribution of carbon in biomass and soils of tropical Asian forests. *Geocarto International* **8(4)**:45-59.
- DeFries, R., G. P. Asner, F. Achard, C. O. Justice, N. LaPorte, K. Price, C. Small, and J. Townshend. 2005. Monitoring tropical deforestation for emerging carbon markets. Pages 35-44 in P. Mountinho and S. Schwartzman, editors. *Tropical Deforestation and Climate Change*. IPAM and Environmental Defense, Belem, Brazil and Washington, DC.
- DeFries, R., R. A. Houghton, M. Hansen, C. Field, D. L. Skole, and J. Townshend. 2002. Carbon emissions from tropical deforestation and regrowth based on satellite observations for the 1980s and 90s. *Proceedings of the National Academy of Sciences* **99**:14256-14261.
- DeGrandi, G., P. Mayaux, Y. Rauste, A. Rosenqvist, M. Simard, and S. Saatchi. 2000. The Global Rain Forest Mapping Project JERS-1 radar mosaic of tropical Africa: Development and product characterization aspects. *IEEE Transactions on Geoscience and Remote Sensing* **38**:2218-2233.
- Drake, J. B., R. G. Knox, R. O. Dubayah, D. B. Clark, R. Condit, J. B. Blair, and M. Hofton. 2003. Above ground biomass estimation in closed canopy Neotropical forests using lidar remote sensing: Factors affecting the generality of relationships. *Global Ecology and Biogeography* **12**:147-159.
- FAO. 2001. *Global Forest Resources Assessment 2000*. FAO Forestry paper 140. Food and Agriculture Organization of the UN, Rome.
- FAO. 2006. *Global Forest Resources Assessment 2005*. FAO Forestry paper 147. Food and Agriculture Organization of the UN, Rome.
- Forest Survey of India. 2004. *State of Forest Report 2003*. Dehra Dun, India.
- Gaston, G., S. Brown, M. Lorenzini, and K. D. Singh. 1998. State and change in carbon pools in the forests of tropical Africa. *Global Change Biology* **4**: 97-114.
- Geist, H. J., and E. F. Lambin. 2002. Proximate causes and underlying forces of tropical deforestation. *BioScience* **52**:143-150.

- Hansen, M. C., R. S. DeFries, J. Townshend, M. Carroll, C. Dimiceli, and R. Sohlberg. 2003. Global percent tree cover at a spatial resolution of 500 meters: First results of the MODIS Vegetation Continuous Fields algorithm. *Earth Interactions* **7**:1-15.
- Hansen, M. C., J. Townshend, R. DeFries, and M. Carroll. 2005. Estimation of tree cover using MODIS data at global, continental and regional/local scales. *International Journal of Remote Sensing* **26**:4359-4380.
- Herold, M., DeFries, R., Achard, F., Skole, D., J. Townshend *et al.* 2006. Report of the workshop on Monitoring Tropical Deforestation for Compensated Reductions, GOFC-GOLD Symposium on Forest and Land Cover Observations, Jena, Germany, 21–22nd March 2006, GOFC-GOLD report series, <http://www.fao.org/gtos/gofc-gold/series.html>.
- Houghton, R.A., K.T. Lawrence, J.L. Hackler, and S. Brown. 2001. The spatial distribution of forest biomass in the Brazilian Amazon: a comparison of estimates. *Global Change Biology* **7**: 731-746.
- Houghton, R. A. 2005. Aboveground forest biomass and the global carbon balance. *Global Change Biology* **11**:945-958.
- INPE. 2005. Monitoramento da Floresta Amazônica Brasileira por Satelite, Projeto PRODES.
- Matricardi, E. A. T., Skole, D. L., Chomentowski, M. A., Cochrane, M. A. 2001. Multi-temporal detection of selective logging in the Amazon using remote sensing. Special Report BRSI Research Advances –Tropical Forest Information Center, Michigan State University No. RA03-01\w, 27p.
- Mayaux P., P. Holmgren, F. Achard, H. Eva, H.-J. Stibig and A. Branthomme, 2005, Tropical forest cover change in the 1990's and options for future monitoring, *Phil. Trans. B* **360**: 373 - 384.
- Mollicone, D., F. Achard, H. Eva, A. Belward, S. Federici, A. Lumericisi, V. C. Risso, H.-J. Stibig, and R. Valentini. 2003. Land use change monitoring in the framework of the UNFCCC and its Kyoto Protocol: Report on current capabilities of satellite remote sensing technology. European Communities, Luxembourg.
- Mollicone, D., F. Achard, S. Federici, H.D. Eva, G. Grassi, A. Belward, F. Raes, G. Seufert, G. Matteucci and E.-D. Schulze. 2006. Avoiding deforestation: An incentive accounting mechanism for avoided conversion of intact and non-intact forests. *Climatic Change*. Submitted.
- Morton, D., R. DeFries, Y. Shimabukuro, L. Anderson, F. Espirito-Santo, M. Hansen, and M. Carroll. 2005. Rapid assessment of annual deforestation in the Brazilian Amazon using MODIS data. *Earth Interactions* **9**:1-22.
- Penman, J., M. Gytarsky, T. Hiraishi, T. Krug, D. Kruger, R. Pipatti, L. Buendia, K. Miwa, T. Ngara, K. Tanabe, and F. Wagner. 2003a. Good Practice Guidance for Land Use, Land-Use Change and Forestry. IPCC National Greenhouse Gas Inventories Programme and Institute for Global Environmental Strategies, Kanagawa, Japan. Available at: <http://www.ipcc-nggip.iges.or.jp/public/gpplulucf/gpplulucf.htm> .
- Penman, J., M. Gytarsky, T. Hiraishi, T. Krug, D. Kruger, R. Pipatti, L. Buendia, K. Miwa, T. Ngara, K. Tanabe, and F. Wagner. 2003b. Definitions and Methodological Options to Inventory Emissions from Direct Human-induced Degradation of Forests and Devegetation of Other Vegetation Types. The Institute for Global Environmental Strategies for the IPCC and The

- Intergovernmental Panel on Climate Change. Hayama, Kanagawa. 32 p. Available at <http://www.ipcc-nggip.iges.or.jp/public/gpplulucf/gpplulucf.htm> .
- Paustian, K., Ravindranath, N. H. and A. van Amstel 2006. Agriculture, Forestry and other land use (AFOLU), in Penman, J., Gytarsky M., Hiraishi, T., Irving, W. and T. Krug: 2006 IPCC Guidelines for National Greenhouse Gas Inventories, Volume 4.
- Ramankutty, N., H. Gibbs, F. Achard, R. DeFries, J. Foley, and R. A. Houghton. In press. Challenges to estimating carbon emissions from tropical deforestation. *Global Change Biology*.
- Rosenqvist, A., V. Taylor, B. Chapman, M. Shimada, A. Freeman, G. DeGrandi, S. Saatchi, and Y. Rauste. 2000. The global rain forest mapping project - a review. *International Journal of Remote Sensing* **21**:1375-1387
- Saatchi, S., R. A. Houghton, R. C. Alvala, J. Soares, and Y. Yu. in press. Distribution of aboveground live biomass in the Amazon Basin. *Global Change Biology*.
- Santilli, M., P. Moutinho, S. Schwartzman, D. C. Nepstad, L. M. Curran, and C. A. Nobre. 2005. Tropical deforestation and the Kyoto Protocol: An editorial essay. *Climatic Change* **71**:267-276.
- Siegert, F., G. Ruecker, A. Hinrichs, and A. Hoffmann. 2001. Increased damage from fires in logged forests during droughts caused by El Niño. *Nature* **414**:437-440.
- Souza Jr., C. M., Roberts, D. and Cochrane, M. A. 2005. Combining Spectral and Spatial Information to Map Canopy Damages from Selective Logging and Forest Fires. *Remote Sensing of Environment*. 98. 329-343.
- Strahler, A. H., L. Boschetti, G. M. Foody, M. Friedl, M. Hansen, M. Herold, P. Mayaux, J. Morissette, S. Stehman, and C. E. Woodcock. 2006. Global Land Cover Validation: Recommendations for Evaluation and Accuracy Assessment of Global Land Cover Maps. European Communities, Luxembourg.
- Townshend, J., and M. Brady. 2006. A Revised Strategy for GOFC-GOLD. GOFC-GOLD report 24. GOFC-GOLD report series, <http://www.fao.org/gtos/gofc-gold/series.html>.
- Tucker, C. J., and J. R. G. Townshend. 2000. Strategies for tropical forest deforestation assessment using satellite data. *International Journal of Remote Sensing* **21**:1461-1472.
- UNFCCC. 2005. Draft conclusions for Agenda item 6: Reducing emissions from deforestation in developing countries UNFCCC/COP-11 draft decision.

APPENDIX ONE: Participants of the GOFC-GOLD workshop held in March 2006 in Jena, Germany

Participant	Institution	Address	Contact
Achard, Frederic	JRC, European Commission	Institute for Environment and Sustainability Joint Research Centre of the European Commission 21020 Ispra (VA), ITALY	Tel: +39 03 32 78 55 45 E-mail: frederic.achard@jrc.it
Brady, Michael	Executive Director GOFC-GOLD Secretariat	Natural Resources Canada Northern Forestry Centre 5320 122 St Edmonton, Alberta T6H 3S5, CANADA	E-mail: mbrady@nrcan.gc.ca
Brown, Sandra	Winrock	Winrock International – Ecosystem Services Unit 1621 N. Kent Street, Suite 1200 Arlington, VA 22207, USA	E-mail: sbrown@winrock.org
Busche, Julia	German Federal Environmental Agency	Umweltbundesamt Fachgebiet I 4.6 Emissionssituation Wörlitzer Platz 1 06844 Dessau, GERMANY	Tel: + 49 (0)340 2103-2494 Fax: + 49 (0)340 2104-2494 E-mail: julia.busche@uba.de
DeSouza, Carlos	Imazon – Amazon Institute of People and the Environment	IMAZON - Instituto do Homem e Meio Ambiente da Amazônia Caixa Postal 1015 CEP Belém-PA 66017-000, BRAZIL	Phone: +1 805-893.4434 E-mail: carlos@geog.ucsb.edu or: souzajr@imazon.org.br
Devers, Didier	OSFAC-Central Africa	OSFAC 6 Avenue Lodja Q/Socimat C/Gombe Kinshasa DEMOCRATIC REPUBLIC OF CONGO	Tel: +243-98695050 E-mail: didier@hermes.geog.umd.edu
Emilio Chuvieco	South America RN	Departamento de Geografía - Universidad de Alcalá Colegios 2 28801 Alcalá de Henares, SPAIN	Tel: +34 918854438 Fax: +34 918854439 E-mail: emilio.chuvieco@uah.es
Erasmí, Stefan	Georg August University Göttingen	Geographisches Institut Abteilung Kartographie, GIS & Fernerkundung Goldschmidtstr. 5 37077 Göttingen, GERMANY	E-mail: serasmi@uni-goettingen.de
Gumbo, Kolethi	SAFNET-Southern Africa	Forestry Commission Chesa Forest Research Station P.O.Box 467 Bulawayo, ZIMBABWE	E-mail: chesa@mweb.co.zw
Grundner, Stefanie	RapidEye	RapidEye Friedrich-Franz-Str. 19 14700 Brandenburg a. d. Havel, GERMANY	Tel: +49 (0)3381 89 04 0 Fax: +49 (0)3381 89 04 101 E-mail: info@rapideye.de
Hansen, Matt	South Dakota State University	Co-Director Geographic Information Science Center of Excellence South Dakota State University Brookings, SD 57007, USA	Tel: +1 605-688-6848 E-mail: Matthew.Hansen@sdstate.edu
Häusler, Thomas	GAF AG München	GAF AG Arnulfstr. 197 D-80634 Munich, GERMANY	E-mail: haeusler@gaf.de

Herold, Martin	GOFC-GOLD Land cover IT office	Department of Geography Friedrich Schiller University Jena Loebdergraben 32 07743 Jena, GERMANY	Tel: +49 (0) 3641 94 88 87 E-mail: m.h@uni-jena.de
Hubald, Robert	Friedrich Schiller University Jena	Department of Geography Friedrich Schiller University Jena Loebdergraben 32 07743 Jena, GERMANY	E-mail: robert.hubald@uni-jena.de
Kanyanga, Joseph K.	SAFNET-Southern Africa (F)	SAFNet Zambia Meteorological Department P.O.Box 30200 Lusaka, 10101 ZAMBIA	Tel: +260 1 252728 E-mail: jk_kanyanga@yahoo.com
Landauer, Kathleen	International START Secretariat	Kathleen Landauer Program Associate International START Secretariat, USA	E-mail: klandauer@aqu.org
Larsen, Murugi	GOFC-GOLD secretariat	Natural Resources Canada Northern Forestry Centre 5320 122 St Edmonton, Alberta T6H 3S5, CANADA	E-mail: mlarsen@nrca.gc.ca
Lawrence, Nsoyuni Ayenika	OSFAC-Central Africa (F)	Assistant Coordinator Global Forest Watch OSFAC Cameroon Focal Point C/o IUCN, Yaounde CAMEROON	Tel: +237 711 0915 Fax: +237 221 97 10 E-mail: ayenikal@iucn.org Nsoyunilawrence@yahoo.com
Mastura Mahmud	SEARRIN-Southeast Asia (F)	Earth Observation Centre Faculty of Social Sciences and Humanities University Kebangsaan Malaysia 43600 UKM BANGI Selangor Darul Ehsan, MALAYSIA	Tel: +3 89216771 Fax: +3 89213334 E-mail: mastura@pkisc.cc.ukm.my
Mayaux, Philippe	JRC, European Commission	Institute for Environment and Sustainability Joint Research Centre of the European Commission 21020 Ispra (VA) ITALY	Tel: +39 0332 78 9706 E-mail: philippe.mayaux@jrc.it
Mollicone, Danilo	Max-Planck Institute for Biogeochemistry	Max-Planck-Institute for Biogeochemistry Hans-Knöll-Str. 10 07745 Jena, GERMANY	E-mail: dmolli@bgc-jena.mpg.de
Mott, Claudius	RSS - Remote Sensing Solutions GmbH	RSS - Remote Sensing Solutions GmbH Woerthstr. 49 81667 Munich, GERMANY	Tel: +49-89-48 95 47 66 Fax: +49-89-48 95 47 67
Murdiyarso, Daniel	Center for International Forestry Research	CIFOR Headquarter P.O. Box 6596, JKPWB Jakarta 10065, INDONESIA	E-mail: d.murdiyarso@cgiar.org
Pandey, Devendra	Director Forest Survey of India	Forest Survey of India (FSI) Ministry of Environment & Forests Kaulagarh Road, P.O., IPE DEHRADUN - 248 195, INDIA	Tel: +91-135-756139, E-mail: dpandeyifs@rediffmail.com
Roswintiarti, Orbita	SEARRIN-Southeast Asia	Jl. LAPAN no. 70 Pekayon - Pasar Rebo Jakarta 13710, INDONESIA	Tel: +(62 21) 8710 274 Fax: +(62 21) 8722 733 oroswin@indo.net.id
Rücker, Gernot	ZEBRIS GbR	ZEBRIS Jürgen Brendel und Gernot Rücker GbR Lipowskystr. 26 81373 München, GERMANY	Tel.: +49 89 58 99 88 86 Fax: +49 89 58 95 86 53 Email: info@zebris.com

Sambale, Jacqueline	GOFC-GOLD Land Cover IT office	Department of Geography Friedrich Schiller University Jena Loebdergraben 32 07743 Jena, GERMANY	Tel: +49 3641 94 88 88 E-mail: jacqueline.sambale@uni-jena.de
Schlamadinger, Bernhard	Joanneum Research	Joanneum Research Elisabethstrasse 5 8010 Graz, AUSTRIA	Tel: +43/(0)316/876 1340 E-mail: bernhard.schlamadinger@joanneum.at
Seifert-Granzin, Joerg	Fundacion Amigos de la Naturaleza, Bolivia	Fundacion Amigos de la Naturaleza Old Highway to Cochabamba Km. 7 Box 2241 Santa Cruz, BOLIVIA	E-mail: jseifert@fanbo.org
Siegert, Florian	Remote Sensing Solutions GmbH	RSS - Remote Sensing Solutions GmbH Wörthstr. 49 81667 München, GERMANY	E-mail: siegert@rssgmbh.de
Siegmund, Robert	GAF AG	GAF AG Arnulfstr. 197 D-80634 Munich, GERMANY	E-mail: siegmund@gaf.de
Skole, Dave	Co-Chair GOFC-GOLD Land Cover IT	Professor and Director Center for Global Change and Earth Observations 101 Manly Miles Building Michigan State University East Lansing, MI 48823, USA	Tel: +1 517 355-1778 E-mail: skole@pilot.msu.edu
Townshend, John	Chair, GOFC-GOLD	Department of Geography Room 2181A, LeFrak Hall University of Maryland College Park, MD 20742, USA	E-mail: jtownshe@geog.umd.edu
Vereau, Vanessa	Consejo Nacional del Ambiente, Peru	Consejo Nacional del Ambiente, Peru Av. Guardia Civil 205 San Borja, Lima, PERU	E-mail: consultorproclim3@conam.gob.pe
Volden, Espen	ESA	ESA-ESRIN Via Galileo Galilei Casella Postale 64 00044 Frascati, ITALY	E-mail: espen.volden@esa.int
Wielgaard, Niels	SarVision	SarVision BV Haagsteeg 4 6708 PM Wageningen, NETHERLANDS	E-mail: wielgaard@sarvision.nl

